



OPERATING INSTRUCTIONS

PA AMPLIFIER

A-1706

A-1712

A-1724

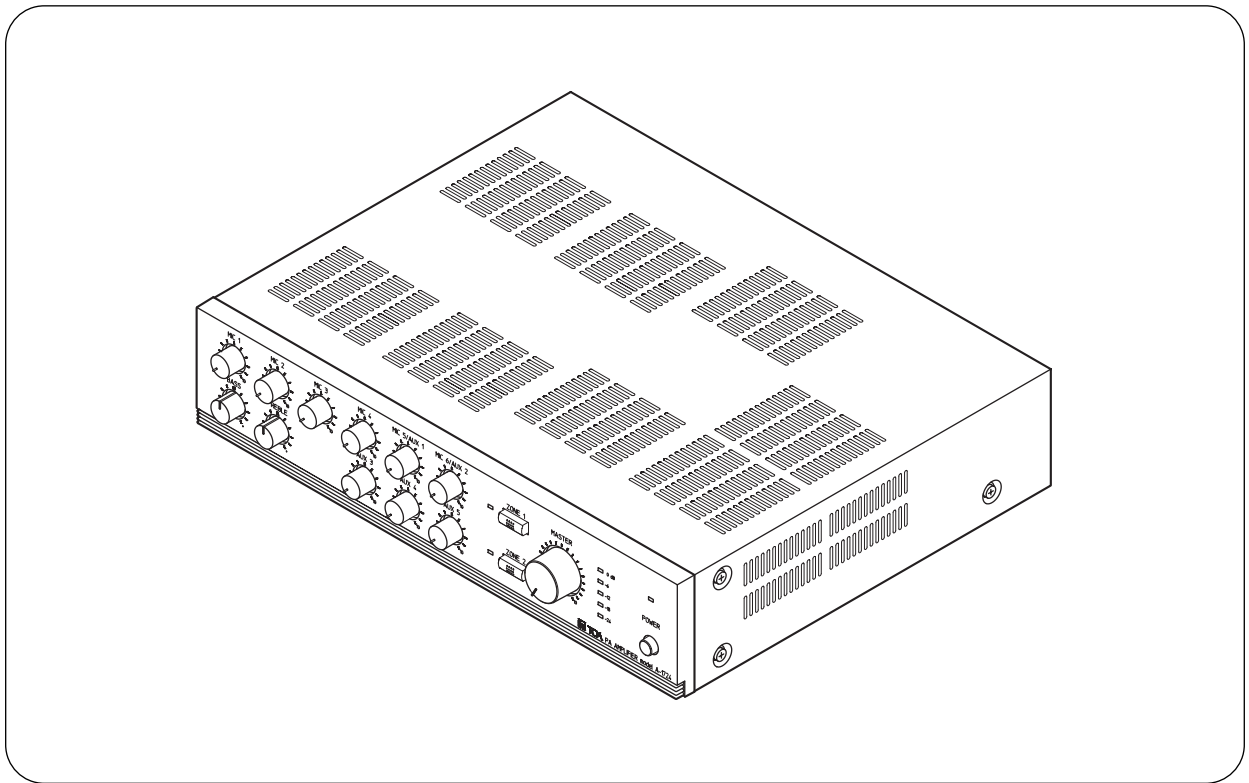

Please follow the instructions in this manual to obtain the optimum results from this unit.
We also recommend that you keep this manual handy for future reference.

TOA Corporation

TABLE OF CONTENTS

1. SAFETY PRECAUTIONS	3
2. GENERAL DESCRIPTION	4
3. FEATURES	4
4. NOMENCLATURE AND FUNCTIONS	
Front	5
Rear	5
5. CONNECTIONS	
5.1. Speaker Connections	7
5.2. Remote Volume Control Connection	7
5.3. Remote Power ON/OFF Control Connection	7
5.4. External Equipment Connection to the LINE OUT and PWR AMP IN Terminals	8
6. FUNCTION SWITCH SETTINGS	8
7. SPEAKER ZONE SELECTION	8
8. INSTALLATION	8
9. RACK MOUNTING	9
10. CONTROL SETTINGS	9
11. BLOCK DIAGRAM	10
12. SPECIFICATIONS	11
Accessories	11
Optional products	11
13. DIMENSIONAL DIAGRAM	12

1. SAFETY PRECAUTIONS

- Be sure to read the instructions in this section carefully before use.
- Make sure to observe the instructions in this manual as the conventions of safety symbols and messages regarded as very important precautions are included.
- We also recommend you keep this instruction manual handy for future reference.

Safety Symbol and Message Conventions

Safety symbols and messages described below are used in this manual to prevent bodily injury and property damage which could result from mishandling. Before operating your product, read this manual first and understand the safety symbols and messages so you are thoroughly aware of the potential safety hazards.



WARNING

Indicates a potentially hazardous situation which, if mishandled, could result in death or serious personal injury.



CAUTION

Indicates a potentially hazardous situation which, if mishandled, could result in moderate or minor personal injury, and/or property damage.



WARNING

When Installing the Unit

- Do not expose the unit to rain or an environment where it may be splashed by water or other liquids, as doing so may result in fire or electric shock.
- Use the unit only with the voltage specified on the unit. Using a voltage higher than that which is specified may result in fire or electric shock.
- Do not cut, kink, otherwise damage nor modify the power supply cord. In addition, avoid using the power cord in close proximity to heaters, and never place heavy objects -- including the unit itself -- on the power cord, as doing so may result in fire or electric shock.
- Be sure to replace the unit's terminal cover after connection completion. Because high voltage is applied to the speaker terminals, never touch these terminals to avoid electric shock.
- Be sure to ground to the safety ground (earth) terminal to avoid electric shock. Never ground to a gas pipe as a catastrophic disaster may result.
- Avoid installing or mounting the unit in unstable locations, such as on a rickety table or a slanted surface. Doing so may result in the unit falling down, causing personal injury and/or property damage.
- The socket-outlet shall be installed near the equipment and the plug (disconnecting device) shall be easily accessible.

When the Unit is in Use

- Should the following irregularity be found during use, immediately switch off the power, disconnect the power supply plug from the AC outlet and contact your nearest TOA dealer. Make no further attempt to operate the unit in this condition as this may cause fire or electric shock.
 - If you detect smoke or a strange smell coming from the unit.
 - If water or any metallic object gets into the unit
 - If the unit falls, or the unit case breaks
 - If the power supply cord is damaged (exposure of the core, disconnection, etc.)
 - If it is malfunctioning (no tone sounds.)
- To prevent a fire or electric shock, never open nor remove the unit case as there are high voltage components inside the unit. Refer all servicing to your nearest TOA dealer.
- Do not place cups, bowls, or other containers of liquid or metallic objects on top of the unit. If they accidentally spill into the unit, this may cause a fire or electric shock.
- Do not insert nor drop metallic objects or flammable materials in the ventilation slots of the unit's cover, as this may result in fire or electric shock.

CAUTION

When Installing the Unit

- Never plug in nor remove the power supply plug with wet hands, as doing so may cause electric shock.
- When unplugging the power supply cord, be sure to grasp the power supply plug; never pull on the cord itself. Operating the unit with a damaged power supply cord may cause a fire or electric shock.
- When moving the unit, be sure to remove its power supply cord from the wall outlet. Moving the unit with the power cord connected to the outlet may cause damage to the power cord, resulting in fire or electric shock. When removing the power cord, be sure to hold its plug to pull.
- Do not block the ventilation slots in the unit's cover. Doing so may cause heat to build up inside the unit and result in fire.
- Avoid installing the unit in humid or dusty locations, in locations exposed to the direct sunlight, near the heaters, or in locations generating sooty smoke or steam as doing otherwise may result in fire or electric shock.

When the Unit is in Use

- Do not place heavy objects on the unit as this may cause it to fall or break which may result in personal injury and/or property damage. In addition, the object itself may fall off and cause injury and/or damage.
- Make sure that the volume control is set to minimum position before power is switched on. Loud noise produced at high volume when power is switched on can impair hearing.
- Do not operate the unit for an extended period of time with the sound distorting. This is an indication of a malfunction, which in turn can cause heat to generate and result in a fire.
- Contact your TOA dealer as to the cleaning. If dust is allowed to accumulate in the unit over a long period of time, a fire or damage to the unit may result.
- If dust accumulates on the power supply plug or in the wall AC outlet, a fire may result. Clean it periodically. In addition, insert the plug in the wall outlet securely.
- Switch off the power, and unplug the power supply plug from the AC outlet for safety purposes when cleaning or leaving the unit unused for 10 days or more. Doing otherwise may cause a fire or electric shock.

An all-pole mains switch with a contact separation of at least 3 mm in each pole shall be incorporated in the electrical installation of the building.

2. GENERAL DESCRIPTION

Equipped with 6 Microphone inputs and 5 AUX inputs (simultaneous use of 9 inputs possible), TOA's A-1706, A-1712, and A-1724 PA Amplifiers are designed to suit PA system applications such as announcements, BGM and broadcasting in mosques, churches, large rooms and factories.

3. FEATURES

- Power output of 60 W (A-1706), 120 W (A-1712), and 240 W (A-1724).
- All microphone inputs are provided with phantom powering (ON/OFF selectable) and electronically-balanced combined XLR/phone jack connectors.
- Convenient 2 zone-selector switches for broadcasting.
- An equalizer or other signal processor connectable between PWR AMP IN and LINE OUT terminals to make fine sound adjustment.
- Tone controls (bass and treble).
- Output level meter.
- Master volume control for overall input signal level adjustment.

4. NOMENCLATURE AND FUNCTIONS

[Front]

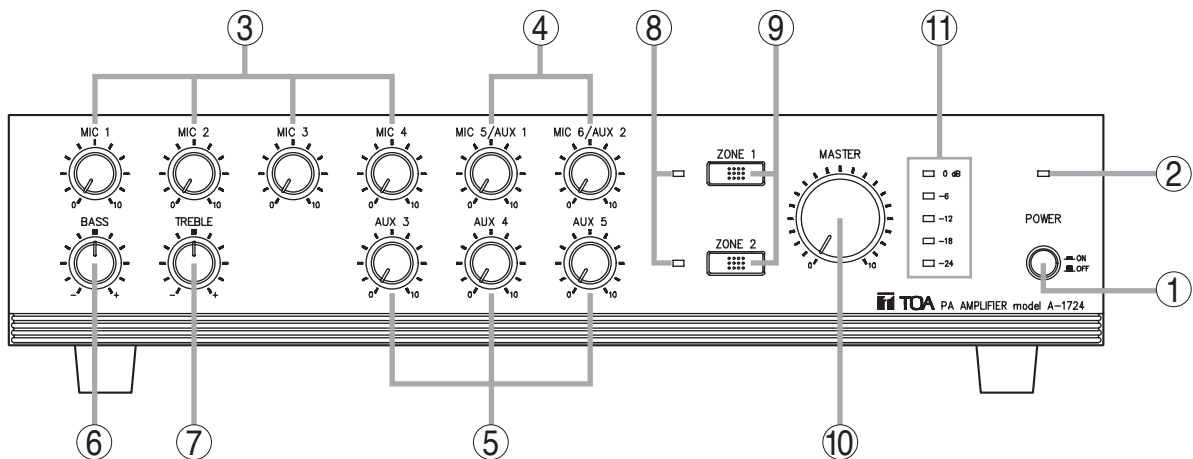

This figure represents the A-1724.

[Rear]

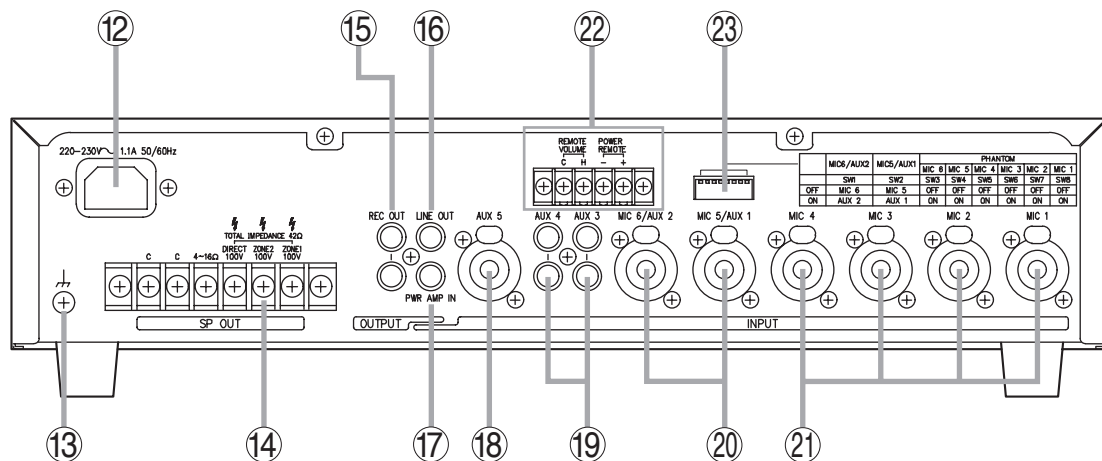

This figure represents the A-1724.

1. Power switch

Press to turn ON the power.
Press again to turn the power OFF.

Note: The unit is not completely disconnected from the power supply even if this Power switch is turned off.

2. Power indicator

Lights green when the power is switched on.

3. Microphone volume controls [MIC 1 – 4]

Adjust the microphone level.

4. Microphone/AUX volume controls [MIC 5/AUX 1, MIC 6/AUX 2]

Adjust the microphone or AUX level.

5. AUX volume controls [AUX 3 – 5]

Adjust the AUX level.

6. Bass control

Adjusts bass response. Rotate clockwise to increase bass output, and counterclockwise to reduce it. The center position provides flat characteristics.

7. Treble control

Adjusts treble response. Rotate clockwise to increase treble output, and counterclockwise to reduce it. The center position provides flat characteristics.

8. Zone indicators

Light to indicate the broadcast zone (zone1, 2) selected with the Zone selector switches.

9. Zone selector switches

Select the desired broadcast zone.
Pressing the ZONE 1 and 2 switches allows the ZONE 1 and 2 output terminals (14) to output signals, respectively.

10. Master volume control

Adjusts the overall signal level.

11. LED level meter

Indicates an output level.

12. AC inlet

Connects to the supplied power cord.

13. Ground terminal

A functional ground terminal.

14. Output terminal block

Connects to speakers. Outputs signals at the ZONE 1 and 2 output terminals when the front-mounted ZONE 1 and 2 switches (9) are pressed, respectively. The DIRECT output terminal continuously outputs signals irrespective of these switch settings.

15. Recording output terminals [REC OUT]

0 dB, 600 Ω, unbalanced. Output all input signals before the master volume control. Connect a cassette deck, etc. when recording the broadcast contents.

16. Line output terminal [LINE OUT]

0 dB, 600 Ω, unbalanced. Outputs all input signals. Connects to a signal processor such as a limiter or equalizer. (Refer to p. 8.)

17. Power amplifier input terminal [PWR AMP IN]

0 dB, 600 Ω, unbalanced. Accepts output signals from the signal processor connected to the Line output terminal (16). (Refer to p. 8.)
Inserting an RCA plug disconnects the internal power amplifier section from the preamplifier section.

18. AUX input terminal [AUX 5]

-20 dB, 10 kΩ, unbalanced. A combined XLR (female)/phone jack connector. Accepts external equipment output signals.

19. AUX input terminals [AUX 3, 4]

-20 dB, 10 kΩ, unbalanced. Monaural RCA pin jacks. Accept external equipment output signals.

20. Microphone/AUX input terminals [MIC 5/AUX 1, MIC 6/AUX 2]

-60 dB, 600 Ω, electronically balanced (MIC 5 and 6) or -20 dB, 600 Ω, electronically balanced (AUX 1 and 2). Combined XLR (female)/phone jack connectors. The input level can be switched between MIC and AUX using the function switch (23).

21. Microphone input terminals [MIC 1 - 4]

-60 dB, 600 Ω, electronically balanced. Combined XLR (female)/phone jack connectors.

Note

Use an XLR connector when connecting a phantom-powered microphone to this terminal. Using a phone plug instead may cause a noise if it is touched or rotated.

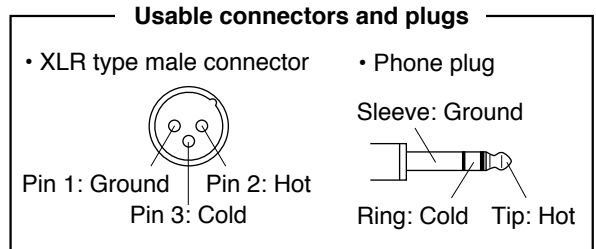

22. Remote control terminal block

- (1) Remote power ON/OFF control input [POWER REMOTE]
Allows remote control of the unit's power ON/OFF.
No-voltage make contact input.
- (2) Remote volume control [REMOTE VOLUME]
Connecting a 10 kΩ linear taper volume control across these terminals will allow remote control of Line output and speaker output levels.

23. Function switch

An 8-bit DIP switch. Selects the following functions:

- (1) Phantom power ON/OFF for each MIC 1-6
- (2) Input sensitivity for MIC 5/AUX 1 and MIC 6/AUX 2
Refer to p. 8 "FUNCTION SWITCH SETTINGS" for details.

5. CONNECTIONS

5.1. Speaker Connections

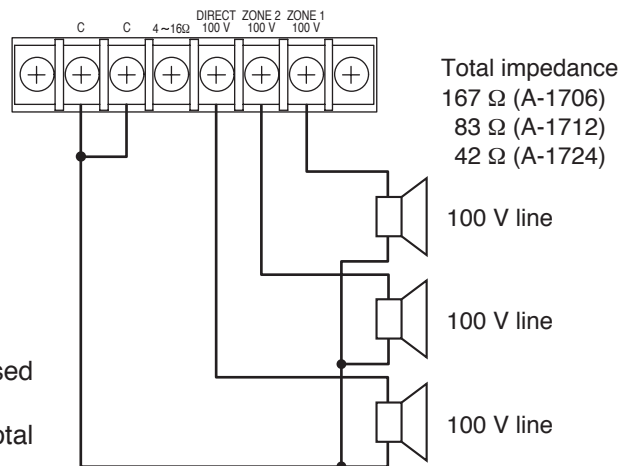
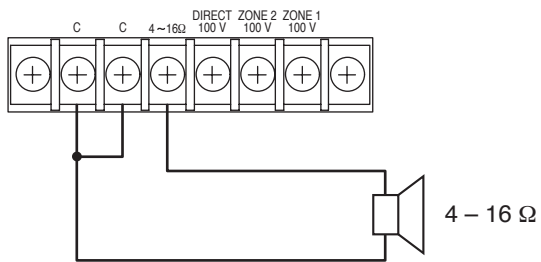

Notes

- Both the 4 – 16 Ω and 100 V terminals cannot be used at the same time.
- Impedances indicated in the figures represent the total speaker system (load) impedances.

⚠ WARNING

Be sure to attach the supplied terminal cover after connection completion. Because high voltage is applied to the speaker terminals, never touch these terminals to avoid electric shock.

5.2. Remote Volume Control Connection

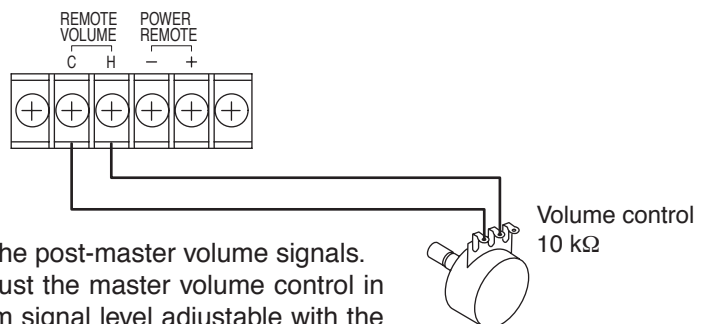

The volume control allows remote adjustment of the post-master volume signals. When performing the remote volume control, adjust the master volume control in advance noting that its setting limits the maximum signal level adjustable with the volume control. Be sure to avoid turning fully down the master volume control.

5.3. Remote Power ON/OFF Control Connection

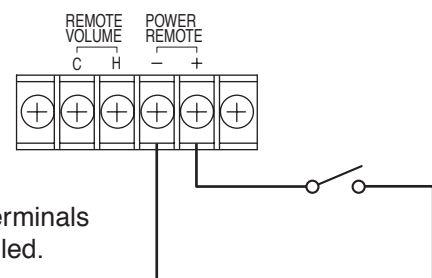

With the unit's power switched OFF, shorting the POWER REMOTE terminals can remotely turn it ON. With ON, the power cannot be remotely controlled.

5.4. External Equipment Connection to the LINE OUT and PWR AMP IN Terminals

By connecting a signal processor such as an equalizer or limiter between the preamplifier section (LINE OUT) and the power amplifier section (PWR AMP IN) of the A-1700 series, signals can be tailored for desired sound output.

Note

Inserting an RCA plug into the PWR AMP IN terminal disconnects the internal power amplifier section from the preamplifier section.

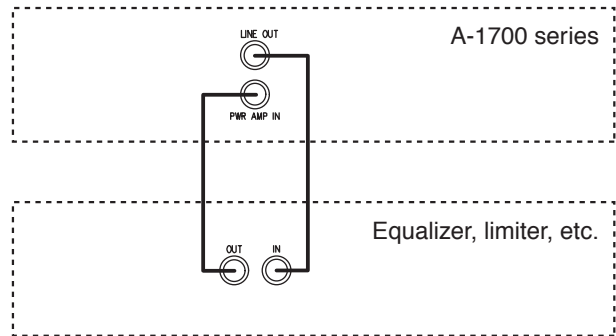

6. FUNCTION SWITCH SETTINGS

Set the rear-mounted Function switch as shown below.



Switch No.	1	2	3	4	5	6	7	8
Function	MIC 6/AUX 2	MIC 5/AUX 1	Phantom Power					
			MIC 6	MIC 5	MIC 4	MIC 3	MIC 2	MIC 1
OFF	MIC 6	MIC 5	OFF	OFF	OFF	OFF	OFF	OFF
ON	AUX 2	AUX 1	ON	ON	ON	ON	ON	ON

7. SPEAKER ZONE SELECTION

Pressing the front-mounted ZONE 1 switch permits its zone indicator to light and makes broadcast through the speakers connected to the rear-mounted Zone 1 output terminals.

Operation for ZONE 2 is performed in the same way as above.

8. INSTALLATION

Keep the unit's all sides over 10 cm away from objects that may obstruct air flow to prevent the unit's internal temperature rise.

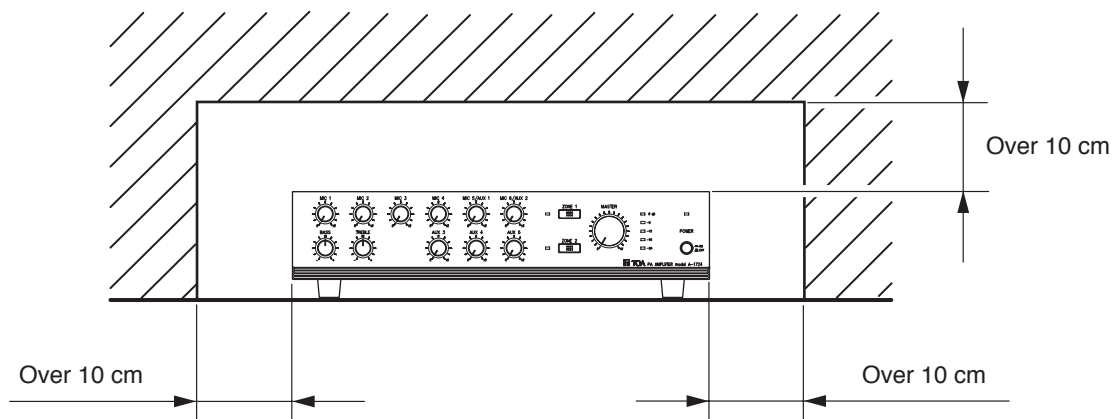

9. RACK MOUNTING

To mount the unit in a standard 19" equipment rack, use the optional MB-25B Rack Mounting Bracket. Attach the MB-25B to the unit using the supplied 4 screws. When using other screws, each screw must be shorter than 16 mm.

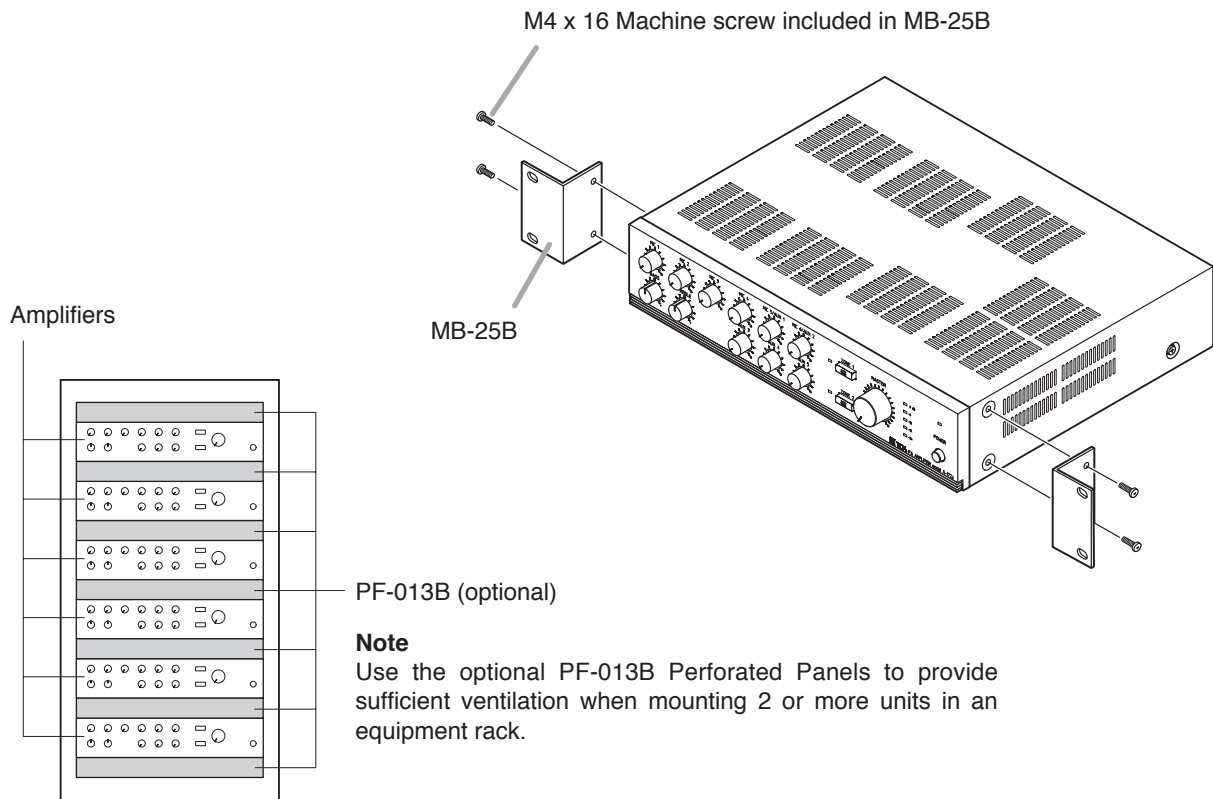

10. CONTROL SETTINGS

Output levels are adjustable with individual volume controls. For music play or announcements, adjust the corresponding volume control so that the red indicator doesn't light. Note that the sound quality is downgraded when the red indicator remains lit.

To prevent the accidental change of the settings of input volume and tone (Bass and Treble) controls, remove their knobs after setting them to the desired position and attach the optional YA-920 Volume Control Covers instead.

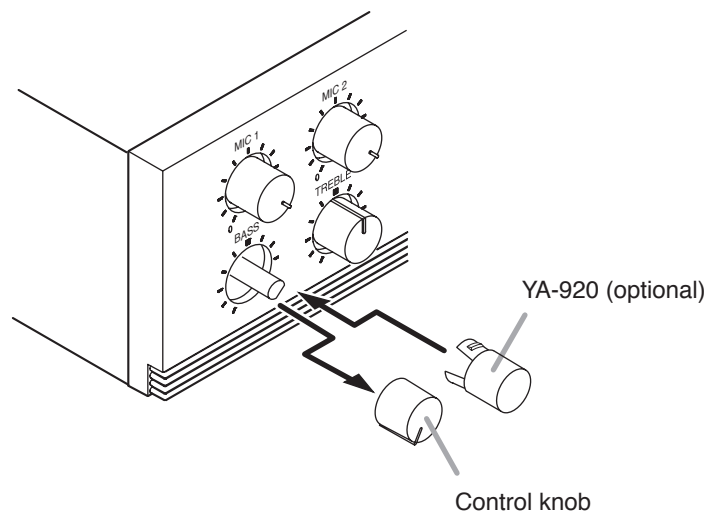

11. BLOCK DIAGRAM

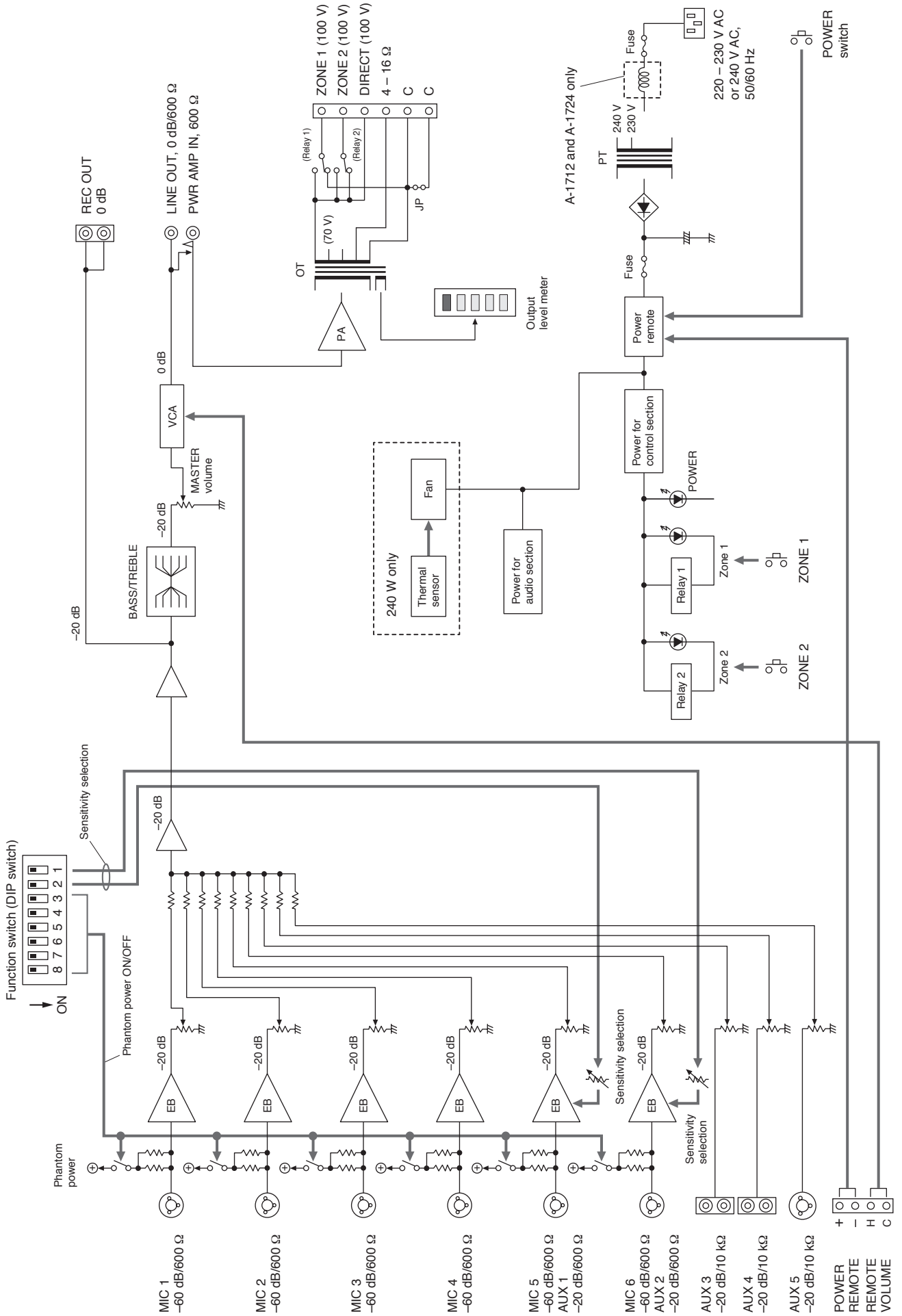

12. SPECIFICATIONS

Model No.	A-1706	A-1712	A-1724
Power Source	220 – 230 V AC or 240 V AC, 50/60 Hz		
Rated Output	60 W	120 W	240 W
Power/Current Consumption	150 W (rated output), 60 W (EN60065) Under 150 mA (when power switch is OFF)	258 W (rated output), 105 W (EN60065) Under 320 mA (when power switch is OFF)	532 W (rated output), 220 W (EN60065) Under 60 mA (when power switch is OFF)
Frequency Response	50 – 20,000 Hz (± 3 dB)		
Distortion	Under 2% at 1 kHz, rated power		
Input	MIC 1 – 6: –60 dB* ¹ , 600 Ω , electronically-balanced, combined type of XLR-3-31 equivalent and phone jack AUX 1 – 2: –20 dB* ¹ , 600 Ω , electronically-balanced, combined type of XLR-3-31 equivalent and phone jack (Either MIC 5 or AUX 1, and either MIC 6 or AUX 2 selectable) AUX 3 – 4: –20 dB* ¹ , 10 k Ω , unbalanced, RCA pin jack AUX 5: –20 dB* ¹ , 10 k Ω , unbalanced, combined type of XLR-3-31 equivalent and phone jack PWR AMP IN: 0 dB* ¹ , 600 Ω , unbalanced, RCA pin jack (An equalizer or other signal processor connectable between LINE OUT and PWR AMP IN terminals)		
Output	REC: 0 dB* ¹ , 600 Ω , unbalanced, RCA pin jack LINE: 0 dB* ¹ , 600 Ω , unbalanced, RCA pin jack SPEAKER SELECTOR: 2 zone, high impedance* ² (100 V line), individual selector key, M4 screw terminal* ³ DIRECT SPEAKER OUT: High impedance* ² (100 V line), M4 screw terminal* ³ , Low impedance (4 – 16 Ω), M4 screw terminal* ³ Note: Both Low and High impedance terminals cannot be used at the same time.		
Phantom Power	ON or OFF for each MIC 1 – 6 with switch setting		
S/N Ratio (Band Pass: 20 – 20,000 Hz)	Over 100 dB (Master volume: min) Over 76 dB (Master volume: max) Over 60 dB (MIC 1 – MIC 4) Over 53 dB (MIC 5, MIC 6) Over 76 dB (AUX 1 – AUX 5)		
Tone Control	Bass: ± 10 dB at 100 Hz, Treble: ± 10 dB at 10 kHz		
Control Input	REMOTE VOLUME: M3 screw terminal* ³ POWER REMOTE: No-voltage make contact input Open voltage: 28 V DC (when the unit's power is OFF) Short-circuit: Under 10 mA, M3 screw terminal* ³		
Indicator	5-point LED output level meter, Power indicator LED, Zone indicator LEDs		
Operating Temperature	–10°C to +40°C		
Finish	Panel: ABS resin, black, hair line Case: Steel plate, black		
Dimensions	420 (w) x 107.7 (h) x 367 (d) mm		
Weight	9.3 kg	12.6 kg	13.5 kg

*¹ 0 dB = 1 V

*² 167 Ω (A-1706), 83 Ω (A-1712), 42 Ω (A-1724)

*³ Distance between barriers on the above screw terminals: 7 mm (M3 screw), 9 mm (M4 screw)

Note: The design and specifications are subject to change without notice for improvement.

• Accessories

AC power cord	1
Terminal cover	1
Terminal cover mounting screw (M4 x 8)	2

• Optional products

Rack mounting bracket: MB-25B
Volume control cover: YA-920
Perforated panel: PF-013B

13. DIMENSIONAL DIAGRAM (Applicable to all models)

Unit: mm

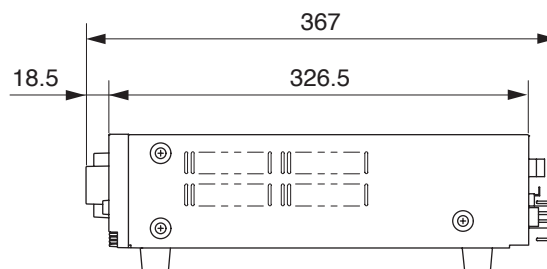
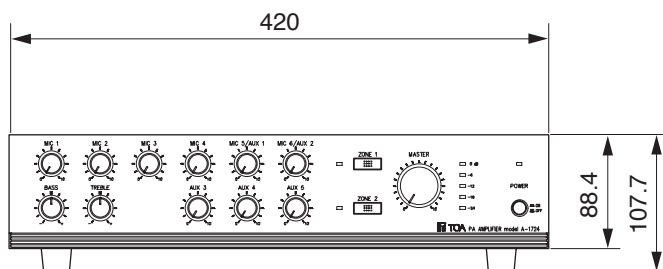
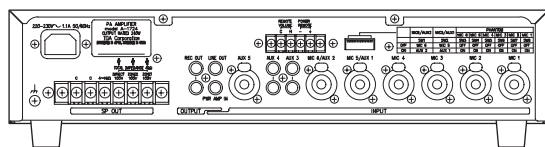

Traceability Information for Europe (EMC directive 2004/108/EC)

Manufacturer:
 TOA Corporation
 7-2-1, Minatojima Nakamachi, Chuo-ku, Kobe, Hyogo,
 Japan

Authorized representative:
 TOA Electronics Europe GmbH
 Suederstrasse 282, 20537 Hamburg,
 Germany